

# RNC 205

## HEAT RECOVERY VENTILATOR



### ENGINEERING DATA

#### THERMALLY CONDUCTIVE, PATENTED ALUMINUM CORE

The counter-flow heat recovery core transfers heat between two airstreams. It is easily removed for cleaning or service.

#### MOTORS AND BLOWERS

Each airstream has an independent centrifugal blower with multiple fan speed operations.

#### FILTERS

Washable air filters in exhaust and supply airstreams.

#### MOUNTING

Four threaded inserts at corners of the cabinet designed to accept the "S" hooks and hanging straps supplied with the unit.

#### DEFROST

Recirculating damper defrost system.

#### CASE

20 gauge prepainted galvanized steel for superior corrosion resistance. Insulated to prevent exterior condensation. Drain connections 2 - 1/2 in. (12 mm) OD. Balancing ports are located on door.

#### INSTALLER SELECTABLE HIGH SPEED SETTINGS

Adjustable DIP switches are located on the circuit board, Hi3 is the factory setting. Refer to the Installation manual for the adjustment instructions.

#### ELECTRONICS

The optional control can be wall mounted in a central location of the home. 3 wire 20 gauge (min.) 100 ft length (max.).

### OPTIONAL ACCESSORIES:

**Dual Hood**  
99-190  
99-194



**Weather Hood**  
99-185  
99-186  
99-187



**TechGrille**  
99-EAG4  
99-EAG5  
99-EAG6  
99-EAG8



**Terminator Fitting**  
99-TM4  
99-TM5  
99-TM6



### LIFEBREATH CONTROL OPTIONS

FEATURES	99-DXPLO2	99-BC02	99-BC03	99-BC04
5 speed fan operation on each mode	✓			
2 speed fan operation (Low/High)		✓		✓
Continuous low speed fan operation	✓	✓	✓	✓
Humidity control through adjustable Dehumidistat	✓	✓	✓	
Large digital LCD screen	✓			
LED status indicator lights		✓	✓	✓
Continuous Ventilation	✓	✓	✓	✓
Continuous Recirculation	✓		✓	
20 ON/40 OFF	✓		✓	✓
10 ON/50 OFF	✓			
20 ON/40 Recirculation	✓		✓	✓
20/40/60 min. High speed override button	✓			
Compatible with 99-DET02 Wireless Timer	✓	✓	✓	✓
3 wire connection	✓	✓	✓	✓

### TIMER OPTIONS

#### 99-DET01 - Lifebreath 20/40/60 Minute Timer

Initiates high speed Ventilation for 20, 40 or 60 minutes. 3 wire connection.

#### 99-DET02 - Wireless Lifebreath 20/40/60 Minute Timer

Initiates high speed Ventilation for 20, 40 or 60 minutes. Wirelessly connects to main control for ease of installation. 40' approximate range. **Exclusive to Lifebreath.**

#### 99-RX02 - Wireless Lifebreath Repeater

Extends range of 99-DET02 Wireless Timers. Plugs into 120V power outlet. Wirelessly connects to main control and 99-DET02. Install at halfway point between timer and main wall control if timer is out of range.



99-BC02

99-BC03

99-BC04

99-DET02

99-DET01

# RNC 205

## HEAT RECOVERY VENTILATOR



### PERFORMANCE (HVI CERTIFIED)

IN. W.G. (PA)	0.2 (50) CFM (L/s)	0.3 (75) CFM (L/s)	0.4 (100) CFM (L/s)	0.5 (125) CFM (L/s)	0.6 (150) CFM (L/s)	0.7 (175) CFM (L/s)	0.8 (200) CFM (L/s)	0.9 (225) CFM (L/s)
Net Supply Airflow	193 (91)	182 (86)	172 (81)	159 (75)	148 (70)	136 (64)	121 (57)	108 (51)
Gross Supply Airflow	197 (93)	186 (88)	174 (82)	163 (77)	150 (71)	138 (65)	123 (58)	108 (51)
Gross Exhaust Airflow	199 (94)	186 (88)	172 (81)	159 (75)	144 (68)	129 (61)	117 (55)	102 (48)

ELECTRICAL SPECIFICATIONS	
VAC @ 60Hz	120
Watts / Low Speed	64
Watts / High Speed	96
Amp Rating	1.4

Sensible Effectiveness (ASE) @ 64 CFM (30 L/s)	32°F (0°C)	85%
Sensible Efficiency (SRE) @ 64 CFM (30 L/s)	32°F (0°C)	76%
Sensible Efficiency (SRE) @ 100 CFM (47 L/s)	32°F (0°C)	73%
Sensible Efficiency (SRE) @ 102 CFM (48 L/s)	-13°F (-25°C)	70%

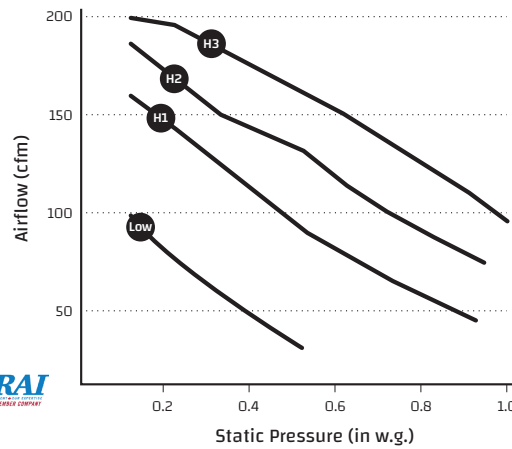

WEIGHT:  
**57 LBS (25.8 KG)**

SHIPPING WEIGHT:  
**67 LBS (30 KG)**

**NOTE:**

Front clearance of 25 in. (635 mm) is recommended for servicing unit. All ducts use 6 in. (150 mm) oval collars, balancing dampers are located on all collars.



### DIMENSIONS

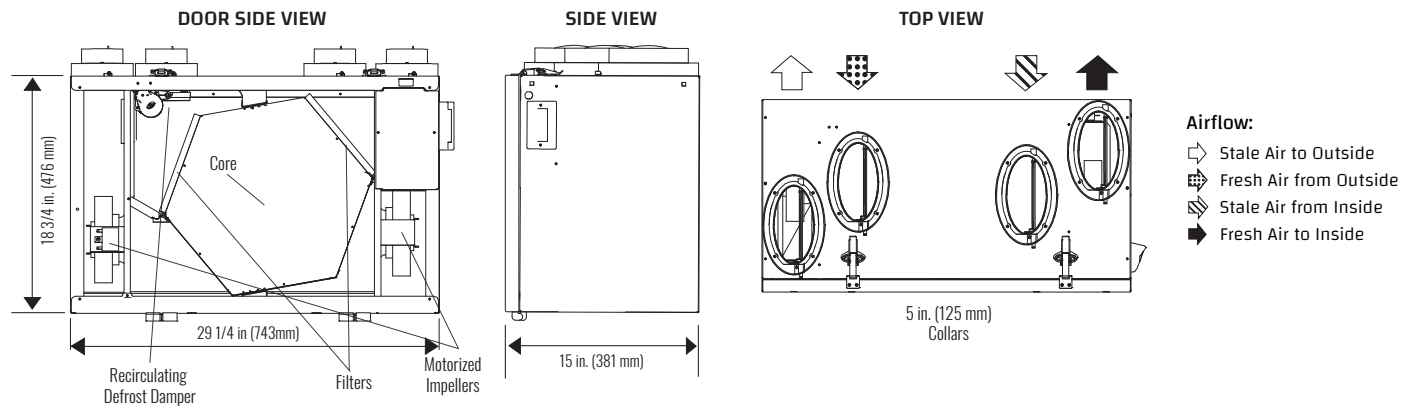

Date: \_\_\_\_\_ Contractor: \_\_\_\_\_

Tag: \_\_\_\_\_ Supplier: \_\_\_\_\_

Project: \_\_\_\_\_ Qty: \_\_\_\_\_ Quote #: \_\_\_\_\_

Engineer: \_\_\_\_\_ Submitted By: \_\_\_\_\_

Control: \_\_\_\_\_ Timer: \_\_\_\_\_ Timer Qty: \_\_\_\_\_

**WARRANTY**  
Units carry a lifetime warranty on the HRV core and a 5 year replacement parts warranty.

All units conform to CSA and UL standards

