

195 DCS HEAT RECOVERY VENTILATOR



ENGINEERING DATA:

THERMALLY CONDUCTIVE, PATENTED ALUMINUM CORES

The cross-flow heat recovery cores transfer heat between two airstreams. The two cores are arranged for highly efficient counter-current airflow. They are easily removed for cleaning or service.

MOTORS AND BLOWERS

Each airstream has an independent centrifugal blower driven by a common PSC motor, with multiple fan speed operations.

FILTERS

Washable MERV-6 air filters in exhaust and supply airstreams. Upgrade to MERV-13 option available.

MOUNTING

Threaded inserts at corners of the cabinet designed to accept the "S" hooks and hanging straps supplied with the unit.

DEFROST

Damper defrost system.

CASE

20 gauge prepainted galvanized steel for superior corrosion resistance, insulated to prevent exterior condensation. Balancing ports are located on unit.

DRAIN CONNECTION

Two 1/2 in (12 mm) outer diameter.

ELECTRONICS

The DXPL02 control included with the unit can be wall mounted in a central location of the home. 3 wire 20 gauge (min.) 100 ft. length (max.).

OPTIONAL ACCESSORIES:

Dual Hood
99-190
99-194



Weather Hood
99-185
99-186
99-187



TechGrille
99-EAG4
99-EAG5
99-EAG6
99-EAG8



Terminator Fitting
99-TM4
99-TM5
99-TM6



LIFEBREATH CONTROL OPTIONS

FEATURES	99-DXPL02	99-BC02	99-BC03	99-BC04
5 speed fan operation on each mode	✓			
2 speed fan operation (Low/High)		✓		✓
Continuous low speed fan operation	✓	✓	✓	✓
Humidity control through adjustable Dehumid-istat	✓	✓	✓	
Large digital LCD screen	✓			
LED status indicator lights		✓	✓	✓
Continuous Ventilation	✓	✓	✓	✓
Continuous Recirculation*	✓		✓	
20 ON/40 OFF	✓		✓	✓
10 ON/50 OFF	✓			
20 ON/40 Recirculation*	✓		✓	✓
20/40/60 min. High speed override button	✓			
Compatible with 99-DET02 Wireless Timer	✓	✓	✓	✓
3 wire connection	✓	✓	✓	✓

*Recirculation features not available on fan defrost models.

69-195 DCS (0921) EN

TIMER OPTIONS

99-DET01 - 20/40/60 Minute Timer

Initiates high speed ventilation for 20, 40 or 60 minutes. 3 wire connection.

99-DET02 - 20/40/60 Minute Timer

Initiates high speed ventilation for 20, 40 or 60 minutes. Wirelessly connects to main control for ease of installation. 40 ft approximate range.

99-RX02 - Wireless Repeater

Extends range of 99-DET02 Wireless Timers. Plugs into 120V power outlet. Wirelessly connects to main control and 99-DET02. Install at halfway point between timer and main wall control if timer is out of range.

INCLUDED WITH ALL MAX UNITS

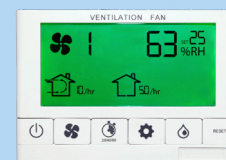

99-DXPL02



99-DET02



99-DET01

LIFEBREATH
Indoor Air Systems

www.lifebreath.com

195 DCS

HEAT RECOVERY VENTILATOR



PERFORMANCE (HVI CERTIFIED)

IN. W.G. (PA)	0.2 (50) CFM (L/s)	0.3 (75) CFM (L/s)	0.4 (100) CFM (L/s)	0.5 (125) CFM (L/s)	0.6 (150) CFM (L/s)	0.7 (175) CFM (L/s)	0.8 (200) CFM (L/s)	0.9 (225) CFM (L/s)
Net Supply Airflow	210 (99)	195 (92)	176 (83)	157 (74)	133 (63)	108 (51)	83 (39)	57 (27)
Gross Supply Airflow	220 (104)	203 (96)	184 (87)	163 (77)	140 (66)	114 (54)	87 (41)	59 (28)
Gross Exhaust Airflow	186 (88)	176 (83)	167 (79)	157 (74)	144 (68)	125 (59)	95 (45)	57 (27)

ELECTRICAL SPECIFICATIONS	
VAC @ 60Hz	120
Watts / Low Speed	74
Watts / High Speed	123
Amp Rating	1.5

Sensible Effectiveness (ASE) @ 73 CFM (35 L/s)	32°F (0°C)	92%
Sensible Efficiency (SRE) @ 64 CFM (30 L/s)	32°F (0°C)	81%
Sensible Efficiency (SRE) @ 95 CFM (45 L/s)	32°F (0°C)	79%
Sensible Efficiency (SRE) @ 114 CFM (54 L/s)	-13°F (-25°C)	68%

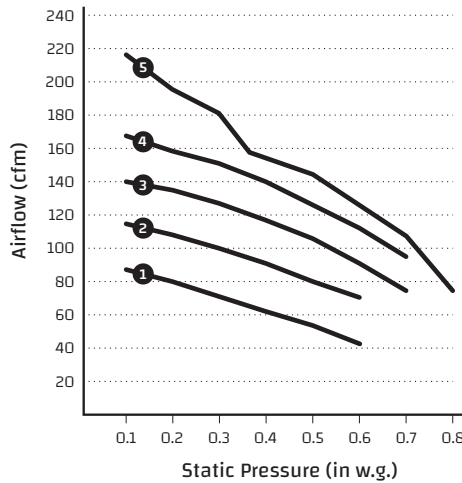

WEIGHT:
88 LBS (40 KG)

SHIPPING WEIGHT:
92 LBS (41.8 KG)

NOTE:

Front clearance of 25 in. (635 mm) is recommended for servicing unit. Outside ports, 6 in. (150 mm). Inside ports, 7 in. (178 mm).

MERV 13 Upgrade: 65-195-6R



DIMENSIONS

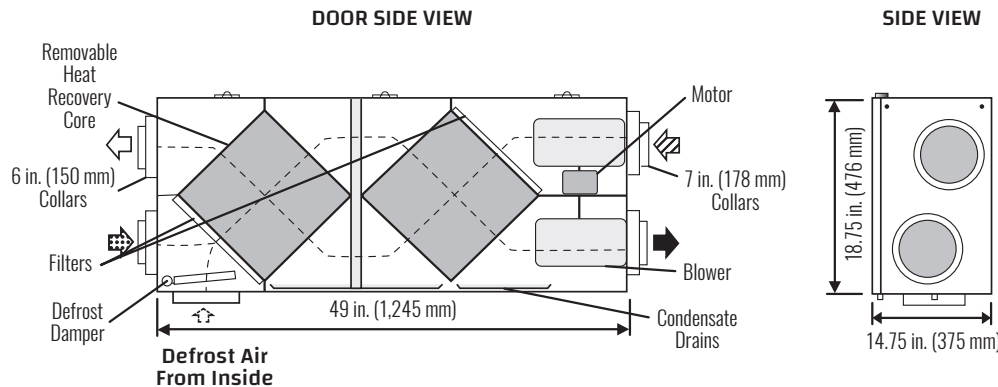

Date: _____ Contractor: _____

Tag: _____ Supplier: _____

Project: _____ Qty: _____ Quote #: _____

Engineer: _____ Submitted By: _____

Control: _____ Timer: _____ Timer Qty: _____

WARRANTY
Units carry a lifetime warranty on the HRV core and a 5 year replacement parts warranty.

All units conform to CSA and UL standards